



气环式真空泵数据表单

展高气泵 卓越品质



G-2RB 系列



气环式真空泵

三相电机 50/60 Hz

真空操作

型号从 2RB 210 到 2RB 590

功率范围：

输出功率：

总压差：

吸气量：

0,25 到 4,0 kW

到 $\Delta p=490$ mbar(P)

80 到 330 m³/h

型号从 2RB 610 到 2RB 790

功率范围：

输出功率：

总压差：

吸气量：

1,6 到 7,5 kW

到 $\Delta p=670$ mbar(P)

265 到 600 m³/h

型号从 2RB 810 to 2RB 943

功率范围：

输出功率：

总压差：

吸气量：

4.0 到 29.0 kW

到 $\Delta p=750$ mbar(P)

500 到 2450 m³/h



订购型号	电机 (IP55)				重量 kg	噪音 dB(A)
	频率 Hz	输出功率 kW	额定			
			电压 V	电流 A		
2RB 210 H06	50	0.25	200-240 Δ /345-415Y	2.1 Δ /1.2Y	9	53
	60	0.29	220-275 Δ /380-480Y	2.0 Δ /1.15Y		56
2RB 210 H16	50	0.4	200-240 Δ /345-415Y	2.6 Δ /1.5Y	10	53
	60	0.5	220-275 Δ /380-480Y	2.6 Δ /1.5Y		56
2RB 220 H26	50	0.7	200-240 Δ /345-415Y	3.8 Δ /2.2Y	15	55
	60	0.83	220-275 Δ /380-480Y	3.75 Δ /2.15Y		61
2RB 230 H06	50	0.25	200-240 Δ /345-415Y	2.1 Δ /1.2Y	10	54
	60	0.29	220-275 Δ /380-480Y	1.7 Δ /1.0Y		57
2RB 230 H16	50	0.4	200-240 Δ /345-415Y	2.6 Δ /1.5Y	11	54
	60	0.5	220-275 Δ /380-480Y	2.6 Δ /1.5Y		57
2RB 230 H26	50	0.7	200-240 Δ /345-415Y	3.8 Δ /2.2Y	12	54
	60	0.83	220-275 Δ /380-480Y	3.8 Δ /2.2Y		57
2RB 310 H06	50	0.55	200-240 Δ /345-415Y	2.8 Δ /1.6Y	11	55
	60	0.63	220-275 Δ /380-480Y	3.0 Δ /1.7Y		57
2RB 310 H16	50	0.75	200-240 Δ /345-415Y	3.8 Δ /2.2Y	12	55
	60	0.83	220-275 Δ /380-480Y	3.8 Δ /2.2Y		57
2RB 320 H26	50	0.85	200-240 Δ /345-415Y	4.2 Δ /2.4Y	17	58
	60	0.95	220-275 Δ /380-480Y	4.0 Δ /2.3Y		60
2RB 320 H36	50	1.3	200-240 Δ /345-415Y	5.7 Δ /3.3Y	18	58
	60	1.5	220-275 Δ /380-480Y	6.0 Δ /3.5Y		60
2RB 330 H06	50	0.55	200-240 Δ /345-415Y	2.8 Δ /1.6Y	12	56
	60	0.63	220-275 Δ /380-480Y	3.0 Δ /1.7Y		58
2RB 330 H16	50	0.75	200-240 Δ /345-415Y	3.8 Δ /2.2Y	13	56
	60	0.83	220-275 Δ /380-480Y	3.8 Δ /2.2Y		58
2RB 410 H06	50	0.7	200-240 Δ /345-415Y	3.8 Δ /2.2Y	13	63
	60	0.83	220-275 Δ /380-480Y	3.75 Δ /2.15Y		64
2RB 410 H16	50	0.85	200-240 Δ /345-415Y	4.0 Δ /2.3Y	16	63
	60	0.95	220-275 Δ /380-480Y	3.85 Δ /2.25Y		64
2RB 410 H26	50	1.3	200-240 Δ /345-415Y	5.7 Δ /3.3Y	17	63
	60	1.5	220-275 Δ /380-480Y	6.0 Δ /3.5Y		64
2RB 420 H36	50	1.6	200-240 Δ /345-415Y	7.5 Δ /4.3Y	25	66
	60	2.05	220-275 Δ /380-480Y	7.6 Δ /4.4Y		69
2RB 420 H46	50	2.2	200-240 Δ /345-415Y	9.7 Δ /5.6Y	27	66
	60	2.55	220-275 Δ /380-480Y	10.0 Δ /5.8Y		69
2RB 430 H06	50	0.7	200-240 Δ /345-415Y	3.8 Δ /2.2Y	14	64
	60	0.83	220-275 Δ /380-480Y	3.8 Δ /2.2Y		65
2RB 430 H16	50	0.85	200-240 Δ /345-415Y	4.2 Δ /2.3Y	17	64
	60	0.95	220-275 Δ /380-480Y	4.0 Δ /2.3Y		65
2RB 430 H26	50	1.3	200-240 Δ /345-415Y	6.6 Δ /3.8Y	18	64
	60	1.5	220-275 Δ /380-480Y	6.9 Δ /4.0Y		65

2RB 490 H16	50	0.6	200-240 Δ /345-415Y	2.8 Δ /1.6Y	14	63
	60	0.85	220-275 Δ /380-480Y	3.6 Δ /2.1Y		64
2RB 510 H06	50	0.85	200-240 Δ /345-415Y	4.0 Δ /2.3Y	20	64
	60	0.95	220-275 Δ /380-480Y	4.2 Δ /2.4Y		70
2RB 510 H16	50	1.3	200-240 Δ /345-415Y	6.6 Δ /3.8Y	22	64
	60	1.5	220-275 Δ /380-480Y	6.9 Δ /4.0Y		70
2RB 510 H26	50	1.6	200-240 Δ /345-415Y	7.5 Δ /4.4Y	23	64
	60	2.05	220-275 Δ /380-480Y	7.6 Δ /1.0Y		70
2RB 510 H36	50	2.2	200-240 Δ /345-415Y	9.7 Δ /5.6Y	25	64
	60	2.55	220-275 Δ /380-480Y	10.3 Δ /6.0Y		70
2RB 520 H46	50	3.0	200-240 Δ /345-415Y	12.5 Δ /7.2Y	40	72
	60	3.45	220-275 Δ /380-480Y	2.6 Δ /7.3Y		74
2RB 520 H57	50	4.0	200-240 Δ /345-415Y	10.0 Δ /5.8Y	44	72
	60	4.6	220-275 Δ /380-480Y	9.9 Δ /5.71Y		74
2RB 530 H06	50	0.85	200-240 Δ /345-415Y	4.0 Δ /2.3Y	21	65
	60	0.95	220-275 Δ /380-480Y	4.2 Δ /2.4Y		71
2RB 530 H16	50	1.3	200-240 Δ /345-415Y	6.6 Δ /3.8Y	23	65
	60	1.5	220-275 Δ /380-480Y	6.9 Δ /4.0Y		71
2RB 530 H26	50	1.6	200-240 Δ /345-415Y	7.5 Δ /4.3Y	24	65
	60	2.05	220-275 Δ /380-480Y	7.6 Δ /4.4Y		71
2RB 530 H36	50	2.2	200-240 Δ /345-415Y	9.7 Δ /5.6Y	26	65
	60	2.55	220-275 Δ /380-480Y	10.3 Δ /6.0Y		71
2RB 590 H26	50	1.1	200-240 Δ /345-415Y	5.7 Δ /3.3Y	23	64
	60	1.7	220-275 Δ /380-480Y	6.0 Δ /3.5Y		70

50 Hz 选型图表

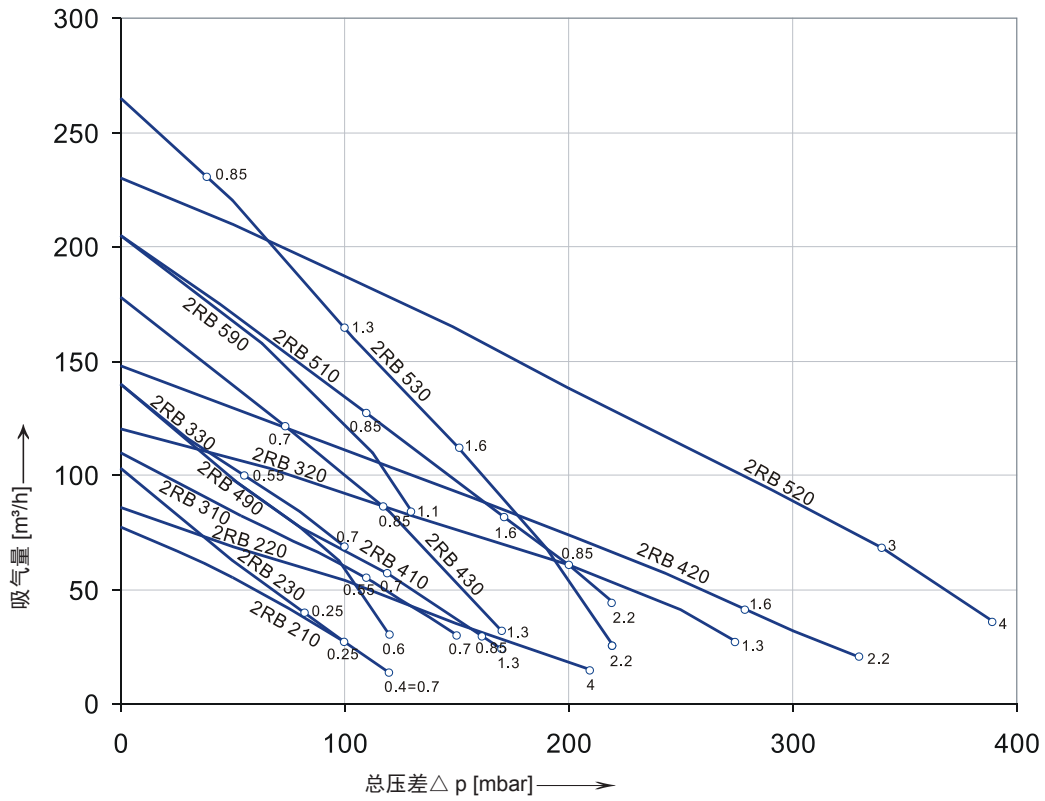

60 Hz 选型图表

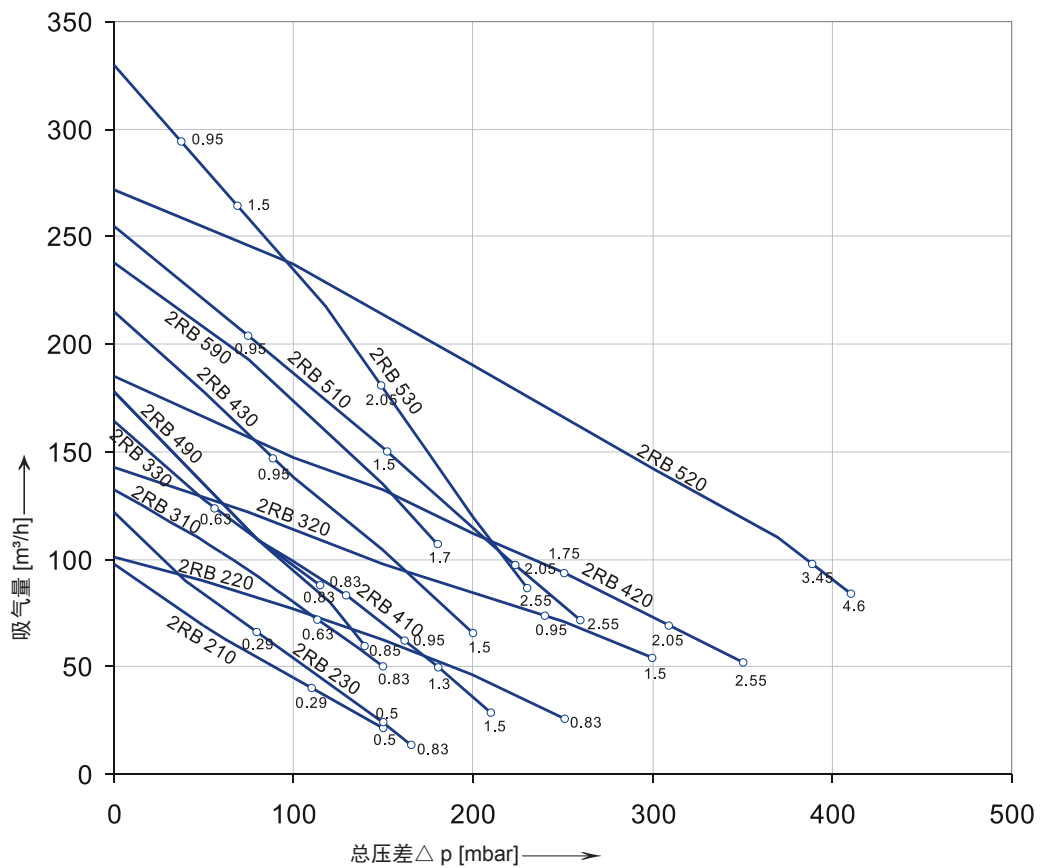

订购型号	电机 (IP55)				重量 kg	噪音 dB(A)
	频率 Hz	输出功率 kW	额定			
			电压 V	电流 A		
2RB 610 H06	50	1.6	200-240 Δ /345-415Y	8.5 Δ /4.9Y	25	68
	60	2.05	220-275 Δ /380-480Y	8.8 Δ /5.1Y		70
2RB 610 H16	50	2.2	200-240 Δ /345-415Y	9.7 Δ /5.6Y	28	69
	60	2.55	220-275 Δ /380-480Y	10.3 Δ /6.0Y		72
2RB 610 H26	50	3.0	200-240 Δ /345-415Y	12.5 Δ /7.2Y	34	69
	60	3.45	220-275 Δ /380-480Y	12.6 Δ /7.3Y		72
2RB 630 H06	50	1.6	200-240 Δ /345-415Y	8.5 Δ /4.9Y	26	70
	60	2.05	220-275 Δ /380-480Y	8.8 Δ /5.1Y		73
2RB 630 H16	50	2.2	200-240 Δ /345-415Y	9.7 Δ /5.6Y	29	70
	60	2.55	220-275 Δ /380-480Y	10.3 Δ /6.0Y		73
2RB 630 H26	50	3.0	200-240 Δ /345-415Y	12.5 Δ /7.2Y	35	70
	60	3.45	220-275 Δ /380-480Y	12.6 Δ /7.3Y		73
2RB 710 H06	50	1.6	200-240 Δ /345-415Y	8.5 Δ /4.9Y	27	69
	60	2.05	220-275 Δ /380-480Y	8.8 Δ /5.1Y		72
2RB 710 H16	50	2.2	200-240 Δ /345-415Y	9.7 Δ /5.6Y	30	69
	60	2.55	220-275 Δ /380-480Y	10.3 Δ /6.0Y		72
2RB 710 H26	50	3.0	200-240 Δ /345-415Y	12.5 Δ /7.2Y	36	69
	60	3.45	220-275 Δ /380-480Y	12.6 Δ /7.3Y		72
2RB 710 H36	50	4.0	345-415 Δ /600-720Y	9.0 Δ /5.2Y	40	63
	60	4.6	380-480 Δ /660-720Y	9.0 Δ /5.2Y		64
2RB 720 H16	50	2.2	200-240 Δ /345-415Y	9.7 Δ /5.6Y	43	73
	60	2.55	220-275 Δ /380-480Y	10.3 Δ /6.0Y		76
2RB 720 H26	50	3.0	200-240 Δ /345-415Y	12.5 Δ /7.2Y	48	73
	60	3.45	220-275 Δ /380-480Y	12.6 Δ /7.3Y		76
2RB 720 H37	50	4.3	345-415 Δ /600-720Y	10.0 Δ /5.2Y	54	73
	60	4.8	380-480 Δ /660-720Y	10.4 Δ /6.0Y		76
2RB 720 H47	50	5.5	345-415 Δ /600-720Y	4.0 Δ /2.3Y	66	73
	60	6.3	380-480 Δ /660-720Y	4.2 Δ /2.4Y		76
2RB 720 H57	50	7.5	345-415 Δ /600-720Y	16.7 Δ /9.6Y	73	73
	60	8.6	380-480 Δ /660-720Y	17.3 Δ /10.0Y		76
2RB 730 H06	50	1.6	200-240 Δ /345-415Y	8.5 Δ /4.9Y	29	70
	60	2.05	220-275 Δ /380-480Y	8.8 Δ /5.1Y		73
2RB 730 H16	50	2.2	200-240 Δ /345-415Y	9.7 Δ /5.6Y	32	70
	60	2.55	220-275 Δ /380-480Y	10.3 Δ /6.0Y		73
2RB 730 H26	50	3.0	200-240 Δ /345-415Y	12.5 Δ /7.2Y	37	70
	60	3.45	220-275 Δ /380-480Y	12.6 Δ /7.3Y		73
2RB 730 H37	50	4.0	345-415 Δ /600-720Y	9.0 Δ /5.2Y	43	70
	60	4.6	380-480 Δ /660-720Y	9.0 Δ /5.2Y		73
2RB 740 H37	50	4.0	345-415 Δ /600-720Y	9.0 Δ /5.2Y	54	74
	60	4.6	380-480 Δ /660-720Y	9.0 Δ /5.2Y		78
2RB 740 H47	50	5.5	345-415 Δ /600-720Y	13.3 Δ /7.7Y	69	74
	60	6.3	380-480 Δ /660-720Y	13.3 Δ /7.7Y		78
2RB 740 H57	50	7.5	345-415 Δ /600-720Y	16.7 Δ /9.6Y	75	74
	60	8.6	380-480 Δ /660-720Y	17.3 Δ /10.0Y		78
2RB 790 H26	50	2.2	200-240 Δ /345-415Y	12.5 Δ /7.2Y	36	69
	60	3.45	220-275 Δ /380-480Y	12.6 Δ /7.3Y		72

50 Hz 选型图表

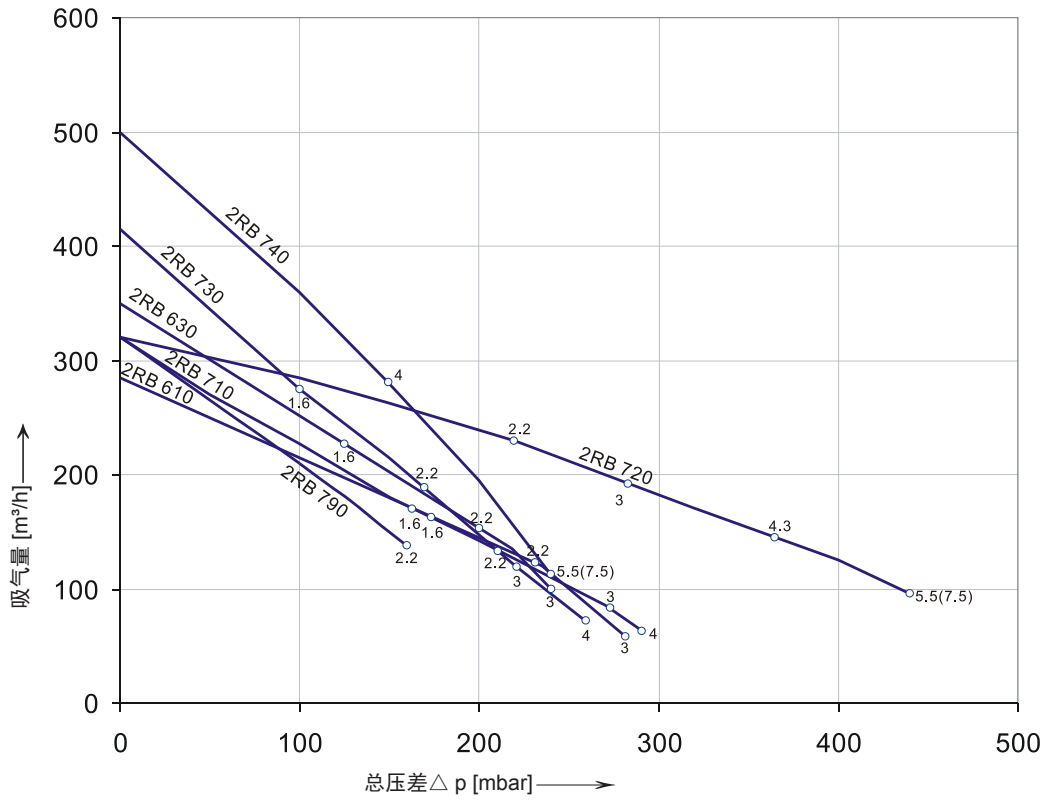

60 Hz 选型图表

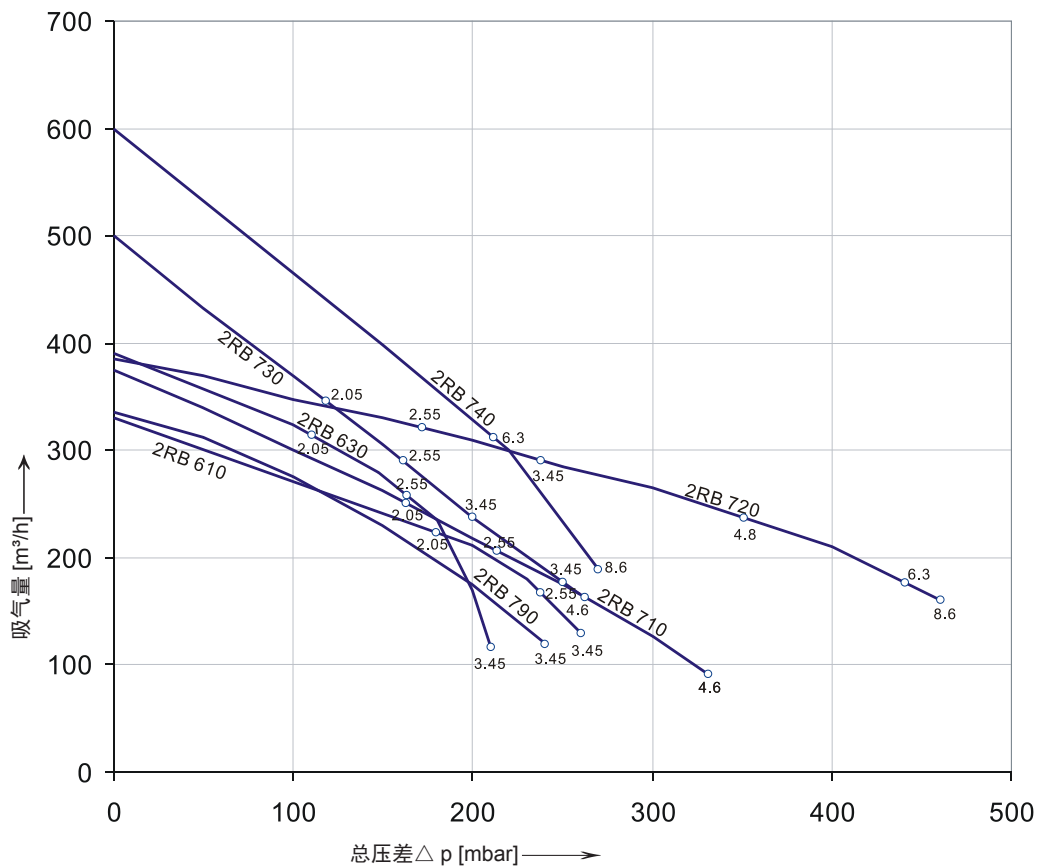

订购型号	电机 (IP55)				重量 kg	噪音 dB(A)
	频率 Hz	输出功率 kW	额定			
			电压 V	电流 A		
2RB 810 H07	50	4.0	345-415 Δ /600-720Y		54	70
	60	4.6	380-480 Δ /660-720Y			74
2RB 810 H17	50	5.5	345-415 Δ /600-720Y		63	70
	60	6.3	380-480 Δ /660-720Y			74
2RB 810 H27	50	7.5	345-415 Δ /600-720Y		66	70
	60	8.6	380-480 Δ /660-720Y			74
2RB 820 H17	50	5.5	345-415 Δ /600-720Y		83	74
	60	6.3	380-480 Δ /660-720Y			78
2RB 820 H27	50	7.5	345-415 Δ /600-720Y		86	74
	60	8.6	380-480 Δ /660-720Y			78
2RB 820 H37	50	11.0	345-415 Δ /600-720Y		104	74
	60	12.6	380-480 Δ /660-720Y			78
2RB 820 H47	50	15.0	345-415 Δ /600-720Y		120	74
	60	17.3	380-480 Δ /660-720Y			78
2RB 830 H07	50	4.0	345-415 Δ /600-720Y		57	70
	60	4.6	380-480 Δ /660-720Y			74
2RB 830 H17	50	5.5	345-415 Δ /600-720Y		66	70
	60	6.3	380-480 Δ /660-720Y			74
2RB 830 H27	50	7.5	345-415 Δ /600-720Y		69	70
	60	8.6	380-480 Δ /660-720Y			74
2RB 840 H27	50	7.5	345-415 Δ /600-720Y		91	74
	60	8.6	380-480 Δ /660-720Y			78
2RB 840 H37	50	11.0	345-415 Δ /600-720Y		110	74
	60	12.6	380-480 Δ /660-720Y			78
2RB 910 H07	50	8.5	345-415 Δ /600-720Y		93	74
	60	9.8	380-480 Δ /660-720Y			79
2RB 910 H17	50	12.5	345-415 Δ /600-720Y		116	74
	60	14.5	380-480 Δ /660-720Y			79
2RB 910 H37	50	18.5	345-415 Δ /600-720Y		126	74
	60	21.3	380-480 Δ /660-720Y			79
2RB 920 H17	50	12.5	345-415 Δ /600-720Y		187	74
	60	14.5	380-480 Δ /660-720Y			84
2RB 920 H27	50	16.5	345-415 Δ /600-720Y		197	74
	60	19.0	380-480 Δ /660-720Y			84
2RB 920 H37	50	20.0	345-415 Δ /600-720Y		204	74
	60	23.0	380-480 Δ /660-720Y			84
2RB 920 H47	50	25.0	345-415 Δ /600-720Y		211	74
	60	29.0	380-480 Δ /660-720Y			84
2RB 930 H07	50	8.5	345-415 Δ /600-720Y		98	75
	60	9.8	380-480 Δ /660-720Y			80
2RB 930 H17	50	12.5	345-415 Δ /600-720Y		121	75
	60	14.5	380-480 Δ /660-720Y			80
2RB 930 H37	50	18.5	345-415 Δ /600-720Y		131	75
	60	21.3	380-480 Δ /660-720Y			80
2RB 940 H27	50	15.0	345-415 Δ /600-720Y		187	75
	60	17.5	380-480 Δ /660-720Y			84
2RB 940 H37	50	20.0	200-240 Δ /345-415Y		212	75
	60	23.0	220-275 Δ /380-480Y			84
2RB 940 H47	50	25.0	345-415 Δ /600-720Y		219	75
	60	29.0	380-480 Δ /660-720Y			84
2RB 943 H27 ¹⁾	50	15.0	345-415 Δ /600-720Y		220	75
	60	17.5	380-480 Δ /660-720Y			84
2RB 943 H37 ¹⁾	50	20.0	345-415 Δ /600-720Y		230	75
	60	25.0	380-480 Δ /660-720Y			84
2RB 943 H47 ¹⁾	50	29.0	345-415 Δ /600-720Y		235	75
	60	6.3	380-480 Δ /660-720Y			84

50 Hz 选型图表

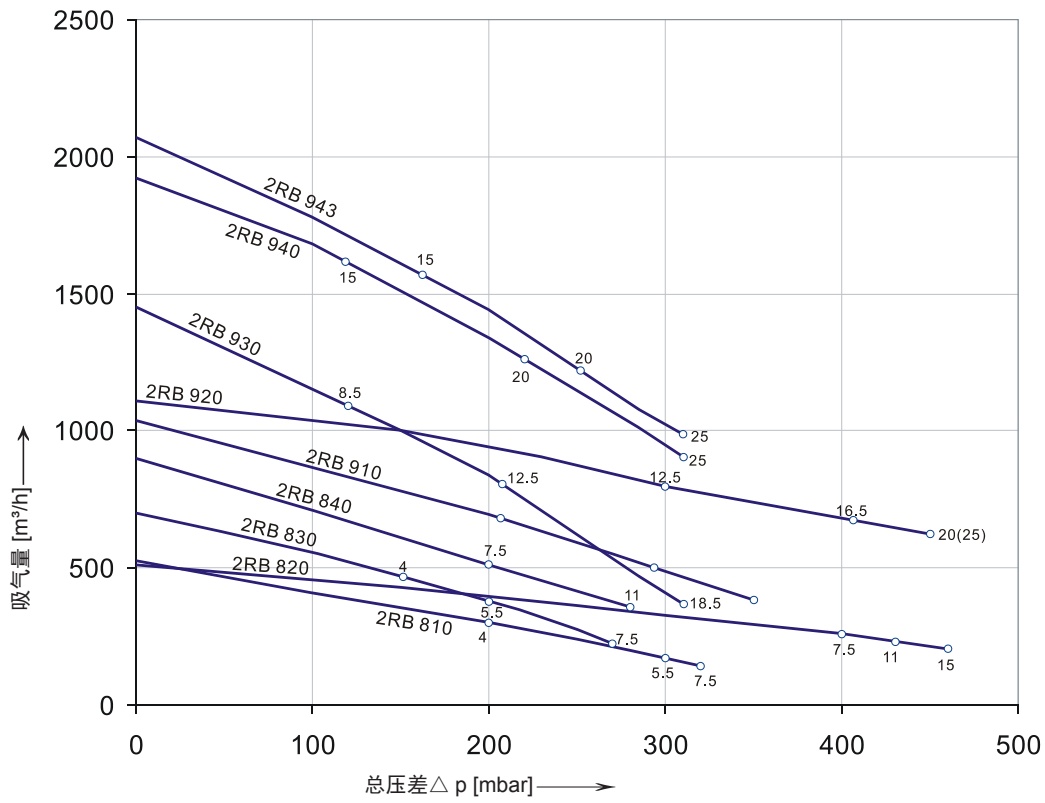

60 Hz 选型图表

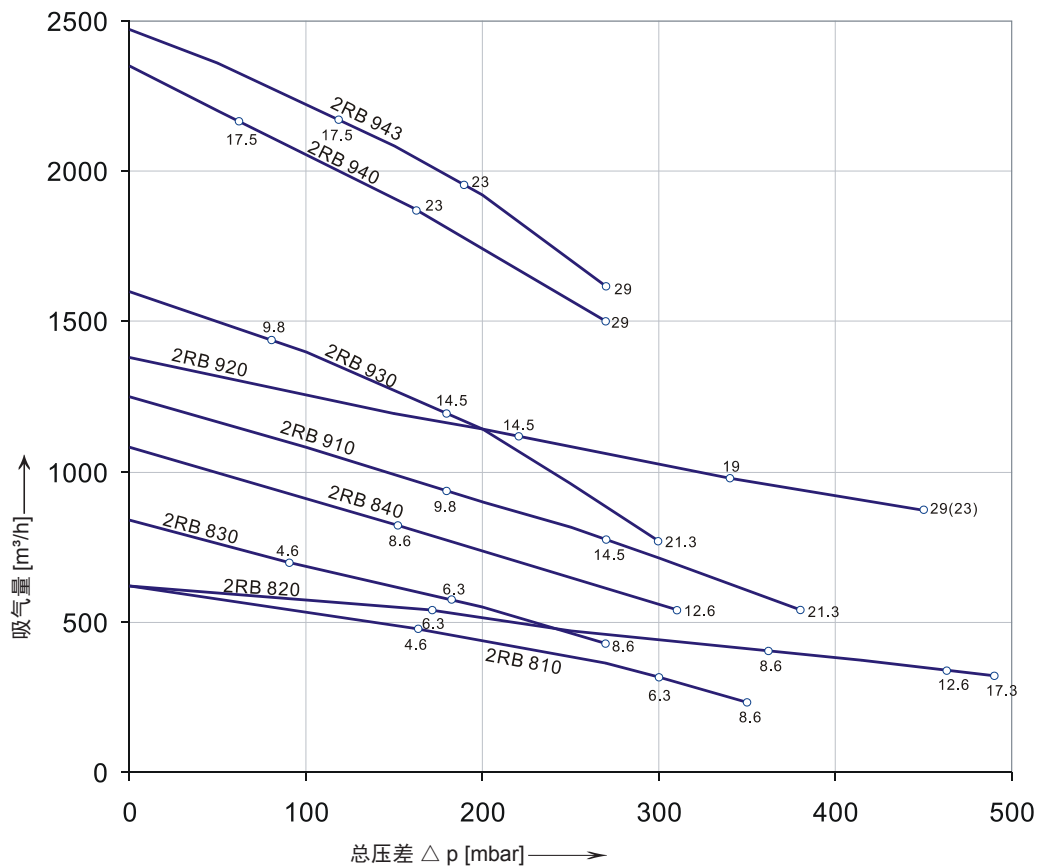

外形尺寸 [mm]

2RB210
2RB230
2RB310
2RB330

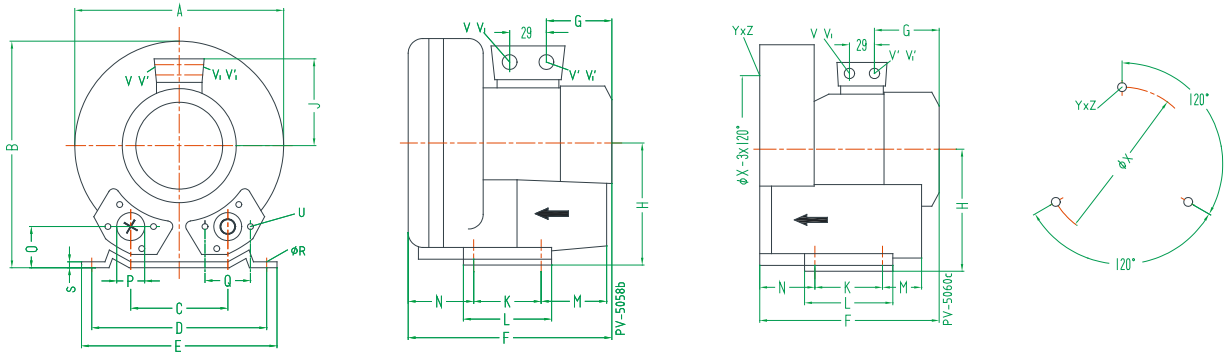

型号	相位	尺寸																	X-孔位								
		A	B	C	D	E	F	G	H	J	K	L	M	N	O	P	Q	φR	S	U	V(t-)	V'(t-)	V(t-s-)	V'(t-s-)	YxZ	φX	
2RB 210 H06	3~	246	247	90	205	230	219	92	128	101	83	108	75	71	39	G1 _{1/4}	64	10	2.5	M6x17	-	-	M25x1.5	M16x1.5	M6x15	0°/120°/240°	140
2RB 210 H16	3~						256	135		111											-	-	M25x1.5	M16x1.5			
2RB 230 H06	3~						242	102		101					82						-	-	M25x1.5	M16x1.5			
2RB 230 H16	3~						267	135		111											-	-					
2RB 230 H26	3~																				-	-					
2RB 310 H06	3~	268	272	93		260			141				82	69	41						-	-	M25x1.5	M16x1.5		160	
2RB 310 H16	3~																				-	-					
2RB 330 H06	3~					276									85						-	-	M25x1.5	M16x1.5			
2RB 330 H16	3~																				-	-					

2RB220
2RB320
2RB420

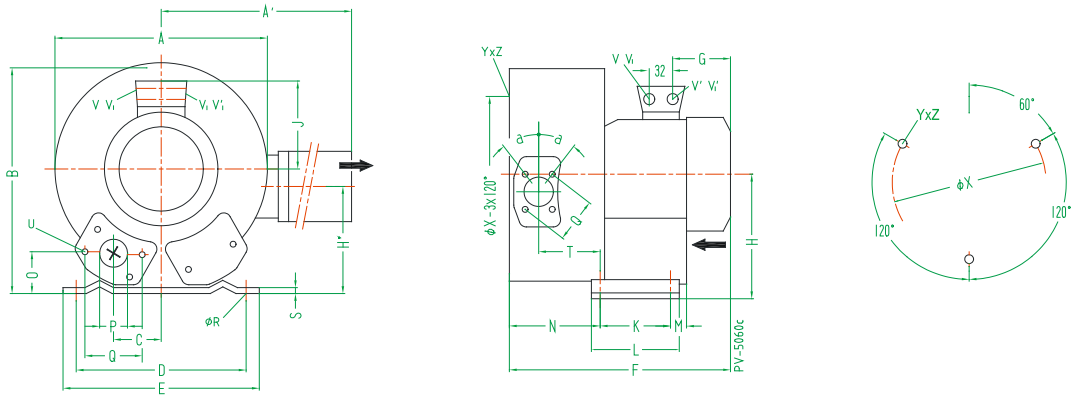

型号	相位	尺寸																	X-孔位												
		A	A'	B	C	D	E	F	G	H	H'	J	K	L	M	N	O	P	Q	φR	S	T	U	V(t-)	V'(t-)	V(t-s-)	V'(t-s-)	α	φX	YxZ	
2RB 220 H26	3~	284	316	270	45	205	230	316	135	128	106	111	83	108	75	130	39	G1 _{1/4} (51ef deep)	64	10	2.5	88	M6x17	-	-	M25x1.5	M16x1.5	27°	140	M6x15	51°/171°/291°
2RB 320 H36	3~	293	324	286	47			354	160	141	114	120			82	138	41					92		-	-			160			
2RB 420 H36	3~	322	324	315	58	225	255	401	191	154	153	128	95	130	73	151	4/5	G1 _{1/2} (51ef deep)	72	12	3	104	M6x19	-	-	M25x1.5	M16x1.5	28°	174		
2RB 420 H46	3~																						-	-							

2RB410
2RB430
2RB490

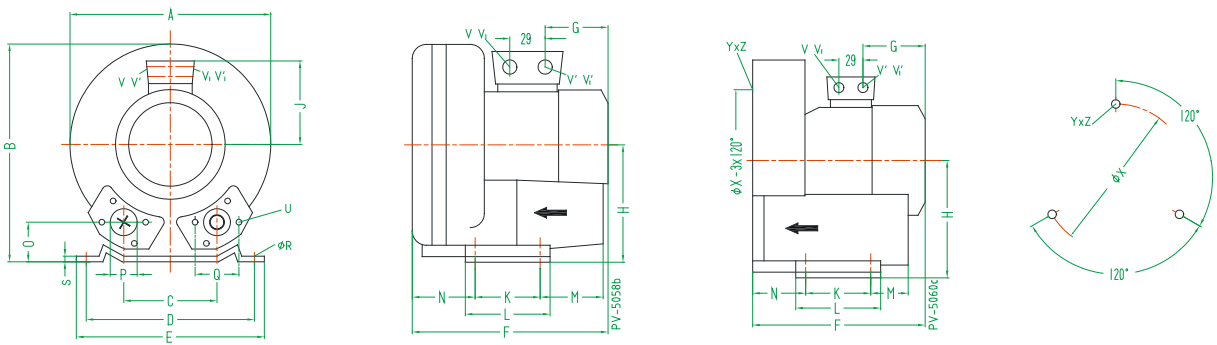

型号	相位	尺寸																	X-孔位				ØX				
		A	B	C	D	E	F	G	H	J	K	L	M	N	O	P	Q	ØR	S	U	V(t+)	V'(t+)		V''(t+)	V'''(t+)	YxZ	
2RB 410 H06	3~	286	302	115	225	255	269	135	154	111	95	130	70	75	46	G1/2	72	12	3	M6x19	-	-	M25x1.5	M16x1.5			174
2RB 410 H16	3~						292	160		120											-	-					
2RB 410 H26	3~																				-	-					
2RB 430 H06	3~						288	135		111											-	-	M25x1.5	M16x1.5			
2RB 430 H16	3~						311	160		120											-	-					
2RB 430 H26	3~																				-	-					
2RB 490 H16	3~						311	160		120											-	-	M25x1.5	M16x1.5			

2RB510
2RB530
2RB590

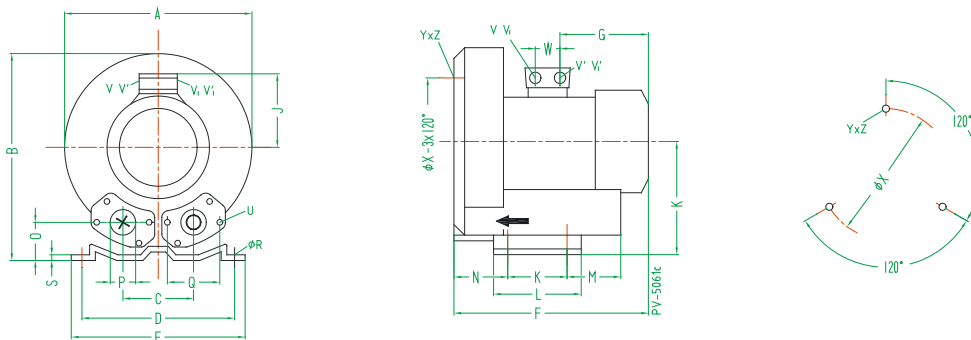

型号	相位	尺寸																	X-孔位			ØX	W					
		A	B	C	D	E	F	G	H	J	K	L	M	N	O	ØP	Q	ØR	S	U	V(t+)			V'(t+)	V''(t+)	V'''(t+)	YxZ	
2RB 510 H06	3~	334	337	120	260	295	314	160	175	120	115	155	96	87	48	55	83	14	4	M8x17	-	-	M25x1.5	M16x1.5	M8x20	0°/120°/240°	200	29
2RB 510 H16	3~																				-	-						
2RB 510 H26	3~						346	191		128											-	-						
2RB 510 H36	3~																				-	-						
2RB 530 H06	3~						334	160		120											-	-	M25x1.5	M16x1.5				
2RB 530 H16	3~																				-	-						
2RB 530 H26	3~						365	191		128											-	-						
2RB 530 H36	3~																				-	-						
2RB 590 H26	3~																				-	-	M25x1.5	M16x1.5				

2RB610
2RB630
2RB710
2RB730
2RB790

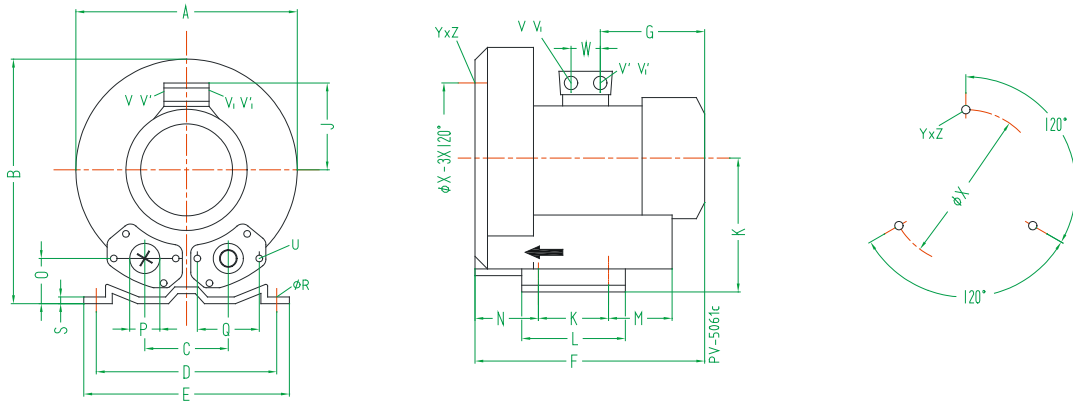

型号	相位																			X-孔位								
		A	B	C	D	E	F	G	H	J	K	L	M	N	O	ØP	Q	ØR	S	U	V(t-)	V(t+)	V(s-)	V(s+)	YxZ	ØX	W	
2RB 610 H06	3~	360	366	122	284	325	354	191	192	128	140	180	64	74	56	56	93	13	4.5	M8x17	-	-	M25x1.5	M16x1.5	M8x20	0°/120°/240°	226	29
2RB 610 H16	3~																											
2RB 610 H26	3~						385	188		135												M32x1.5	M32x1.5	M32x1.5	M32x1.5			42
2RB 630 H06	3~						372	191		128																		29
2RB 630 H16	3~																											
2RB 630 H26	3~						403	188		135																		42
2RB 710 H06	3~	382	384	125	290		377	191	197	128				84	109	54	55	83	15						M10x20		240	29
2RB 710 H16	3~																											
2RB 710 H26	3~						409	188		135																		42
2RB 710 H37	3~						432	209		148																		
2RB 730 H06	3~						387	191		128																		29
2RB 730 H16	3~																											
2RB 730 H26	3~						419	189		135																		42
2RB 730 H37	3~						432	209		148																		
2RB 790 H26	3~						377	185		128																		29

2RB520-...4.
...5.
2RB720-...1.
...2.
...3.

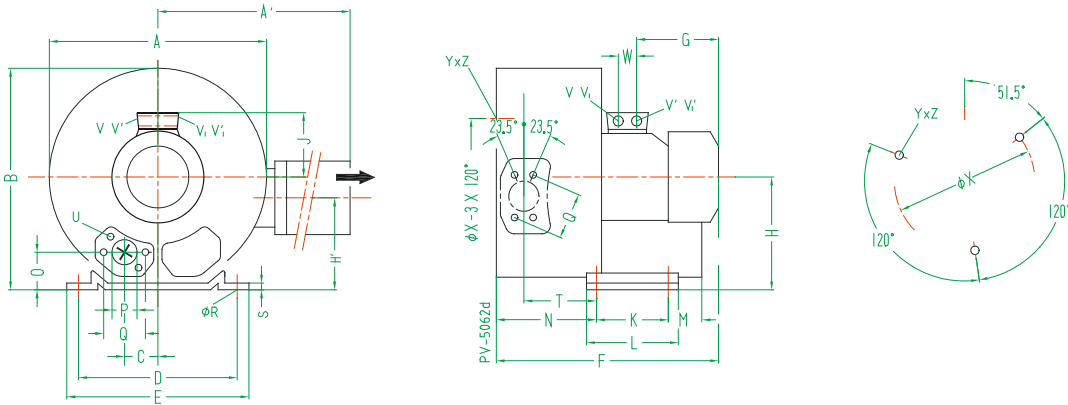

2RB720-...4
...5

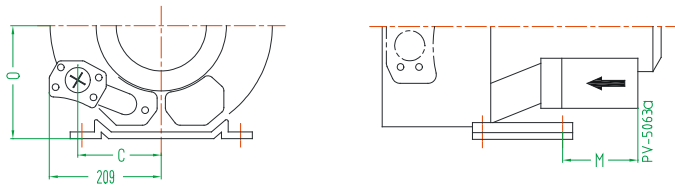

型号	相位																									X-孔位					
		A	A'	B	C	D	E	F	G	H	H'	J	K	L	M	N	O	ØP	Q	ØR	S	T	U	V	V'	V1	V1'	ØX	YxZ	W	
2RB 520 H46	3~	372	411	371	60	260	295	465	190	175	144	135	115	155	98	171	48	55	83	14	4	116	M6x17	M32x1.5	M32x1.5	M32x1.5	M32x1.5	200	M8x20	51.5°/117.5°/291.5°	42
2RB 520 H57	3~							499	224																						
2RB 720 H16	3~	426	426	410	63	290	325	473	191	162	128	140	180	84	205	53								M25x1.5	M16x1.5	-	-	240	M10x20		29
2RB 720 H26	3~							496	188		135														M32x1.5	M32x1.5	M32x1.5	M32x1.5			42
2RB 720 H37	3~							526	209		148																				
2RB 720 H47	3~				154	290		571	226		167				200																
2RB 720 H57	3~																														

2RB740-...3.

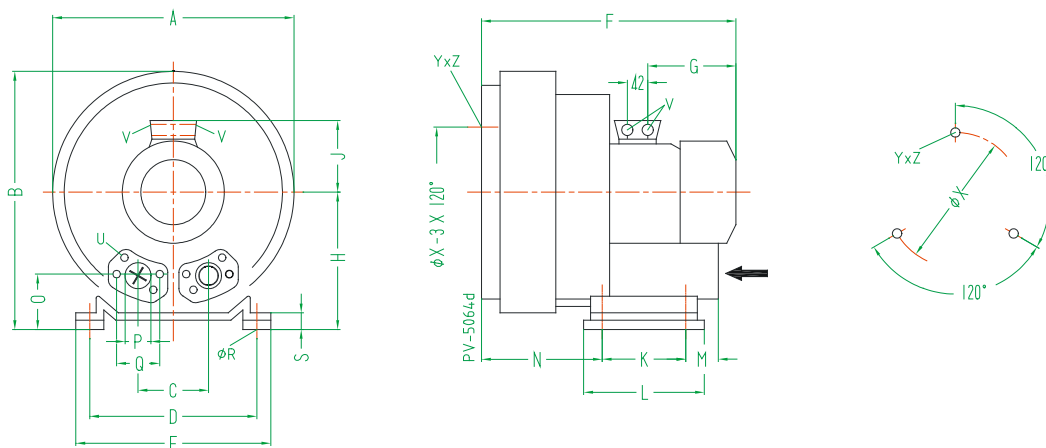

2RB740-...4
-...5

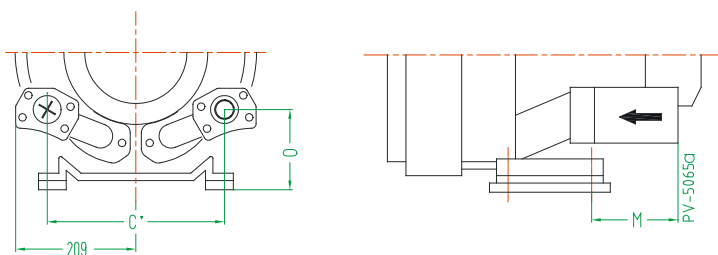

型号	相位	尺寸																			X-孔位				
		A	B	C	C'	D	E	F	G	H	J	K	L	M	N	O	ØP	Q	ØR	S		U	V	ØX	YxZ
2RB 740 H37	3~	420	410	125	-	290	325	526	209	197	148	140	180	84	205	153	55	83	15	64.5	M8x17	4xM32x1.5	240	M10x20	0°/120°/240°
2RB 740 H47	3~			-	308			571	226	257	167			200											
2RB 740 H57	3~			-																					

2RB810./2RB830

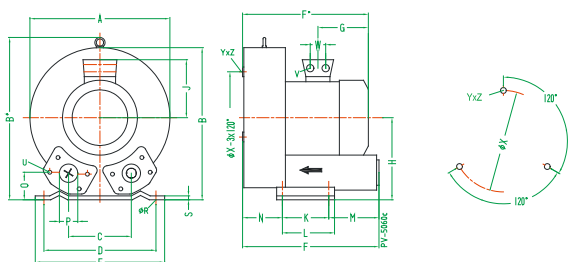

2RB820-...1.
-...2.

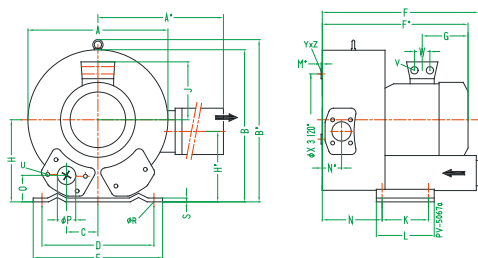

2RB820-...3.
-...4.

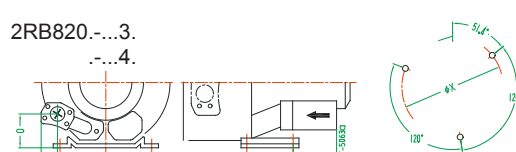

型号	相位	尺寸																							X-孔位			
		A	A'	B	B'	C	D	E	F	F'	G	H	H'	J	K	L	M	N	N'	O	ØP	ØR	S	V		W	ØX	YxZ
2RB 810 H07	3~	451	-	461	509	152	356	394	433	450	230	240	-	148	170	217	140	124	-	65	G2/12	15	6	4xM32x1.5	42	286	M12x20	0°/120°/240°
2RB 810 H17	3~									477	226			167														
2RB 810 H27	3~																											
2RB 820 H17	3~	500	549	490	509	76		545	589					199					-	236	84							51.4°/120°/240°
2RB 820 H27	3~																											
2RB 820 H37	3~									694	318			197					-	212	105			4xM40x1.5	54			
2RB 820 H47	3~																											
2RB 830 H07	3~	451	-	461	509	152		449	466	230			148			139	164	-	65				4xM32x1.5	42				0°/120°/240°
2RB 830 H17	3~									492	247			167														
2RB 830 H27	3~																											

2RB840-...2.

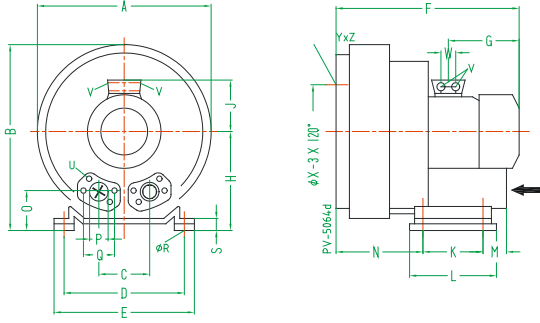

2RB840-...3.

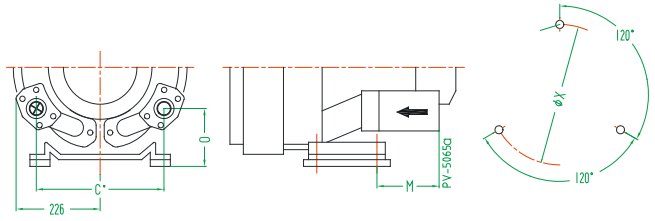

型号	相位																				X-孔位			
		A	B	C	C'	D	E	F	G	H	J	K	L	M	N	O	φP	φR	S	V		W	φX	YxZ
2RB 840 H27	3~	500	550	152	-	356	394	589	247	300	167	170	217	-	236	125	G2/2	15	66	4xM32x1.5	42	286	M12x20	0°/120°/240°
2RB 840 H37	3~					336		694	318		197				312	212	165			4xM40x1.5	54			

2RB910./930

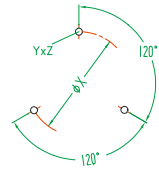
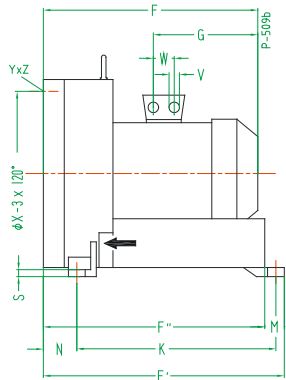
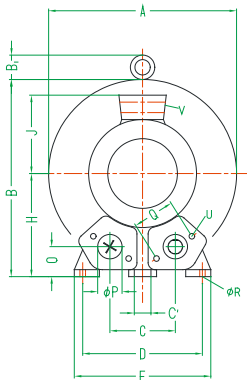

型号	相位																								X-孔位			
		A	B	B1	C	C'	D	E	F	F'	F''	G	H	J	K	M	N	O	φP	Q	φR	S	U	V		W	φX	YxZ
2RB 910 H07	3~	550	569	55	207	15	360	415	525	644	605	268	300	167	533	39	89	92	100	150	15	21	M12x30	4xM32x1.5	42	490	M12x30	0°/120°/240°
2RB 910 H17	3~								611			345		197										4xM40x1.5	54			
2RB 910 H37	3~																											
2RB 930 H07	3~								563	682	643	268		167			127							4xM32x1.5	42			
2RB 930 H17	3~								649			345		197										4xM40x1.5	54			
2RB 930 H37	3~																											

2RB920.

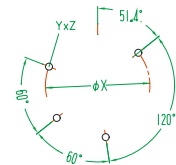
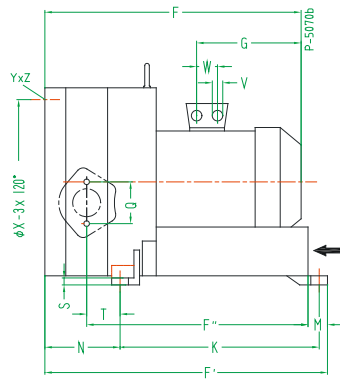
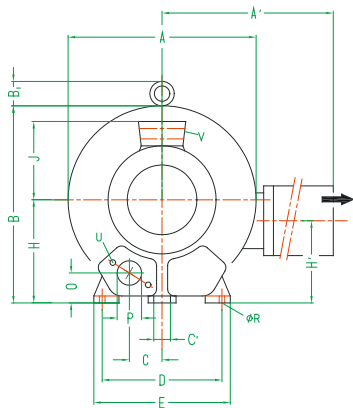

型号	相位																								X-孔位							
		A	A'	B	B1	C	C'	D	E	F	F'	F''	G	H	H'	J	K	M	N	O	φP	Q	φR	S		T	U	V	W	φX	YxZ	
2RB 920 H17	3~	615	780	607	16	103.5	15	360	415	752	786	634	345	300	234	197	533	39	230	92	100	150	15	21	117	M12x30	4xM40x1.5	54	490	M12x30	51.4°/120°/240°	
2RB 920 H27	3~																															
2RB 920 H37	3~																															
2RB 920 H47	3~								812																							

2RB940.

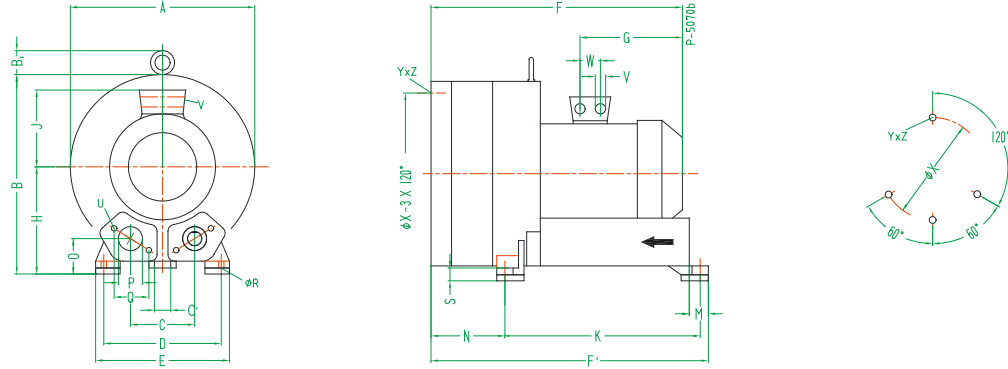

型号	相位	尺寸																			X-孔位						
		A	B	B ₁	C	C'	D	E	F	F'	G	H	J	K	M	N	O	φP	Q	φR		S	U	V	W	φX	YxZ
2RB 940 H27	3~	615	657	16	207	15	360	415	752	786	345	350	197	533	39	280	142	100	140	15	71	M12x35	4xM40x1.5	54	490	M12x30	120°/60°/60°
2RB 940 H37	3~																										
2RB 940 H47	3~								812																		

2RB943.

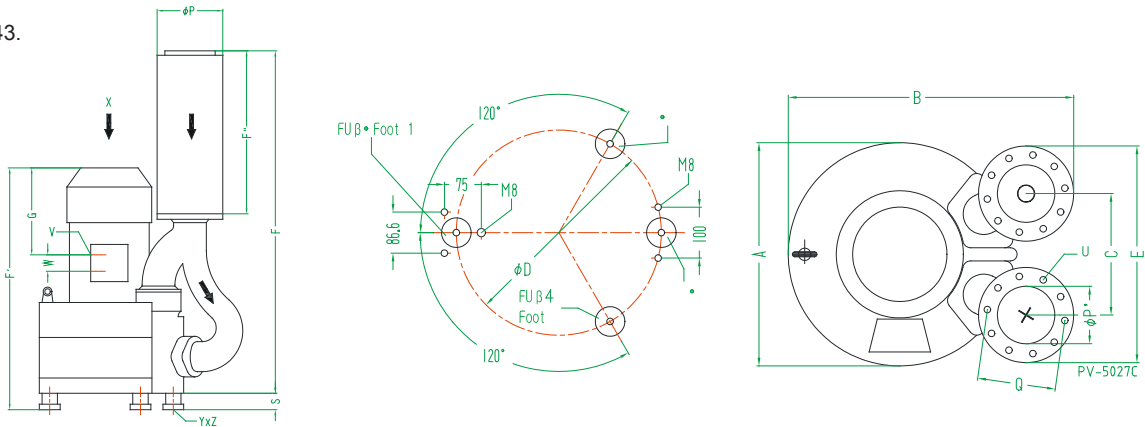

型号	相位	尺寸																
		A	B	C	D	E	F	F'	F''	G	P	P'	Q	S	U	V	W	YxZ
2RB 943 H27 ¹⁾	3~	615	723	307	490	526	1201	848	578	291	219	135	201	58	M8x40	4xM40x1.5	54	M12x10.5
2RB 943 H37 ¹⁾	3~																	
2RB 943 H47 ¹⁾	3~							908	351									

2RB 943:
紧用于在前改的安装

性能曲线:

性能曲线是在抽取 15°C 空气，排气压力 1013mbar 的工况下测出的，允差 ±10%，吸入空气和环境温度不超过 25°C 时，极可达到图示总压差。

噪音:

测量 - 表面噪音 - 压力按照 DIN EN 21680 标准。测量距离是 1 米，气泵的出风口（压力）和进气口（真空）各连接一条软管，但是不安装释压阀。

声明:

关于特别引述的性能曲线，数据和重量的变化，恕不另行通知。